

Test Terminal Block

Series - NWKB



FEATURES

- Facilitates easy & safe in-situ testing of C. T. operated metering systems without disrupting load circuit.
- Robust construction.
- High electrical strength.
- Facilitates injecting voltage from external source by using Banana Plugs.
- Easy sealing arrangement.
- Bridging Link option available for earthing of current returns with C-phase. Return of current thus connected to earth.
- Extended robust transparent Cover.

Ordering Codes :

Type	Code
Test Terminal Block. Front connected. Without Bridging Link	NWKB/FC-01
Test Terminal Block. Front connected. With Bridging Link	NWKB/FC-02

Bridging Link

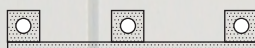

Circuit Diagram

- Secondary Conductors
Current Circuit Wiring - 4mm²
- Voltage Circuit Fuses - 10A HRC
- Voltage Circuit Wiring
4 mm²

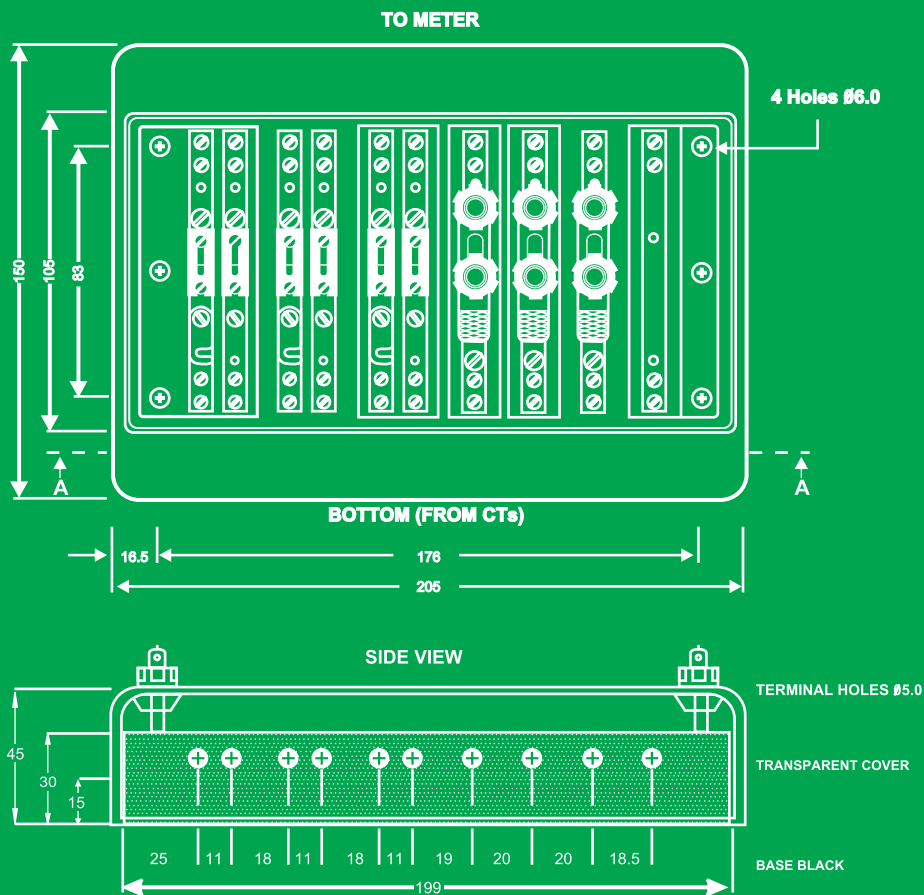
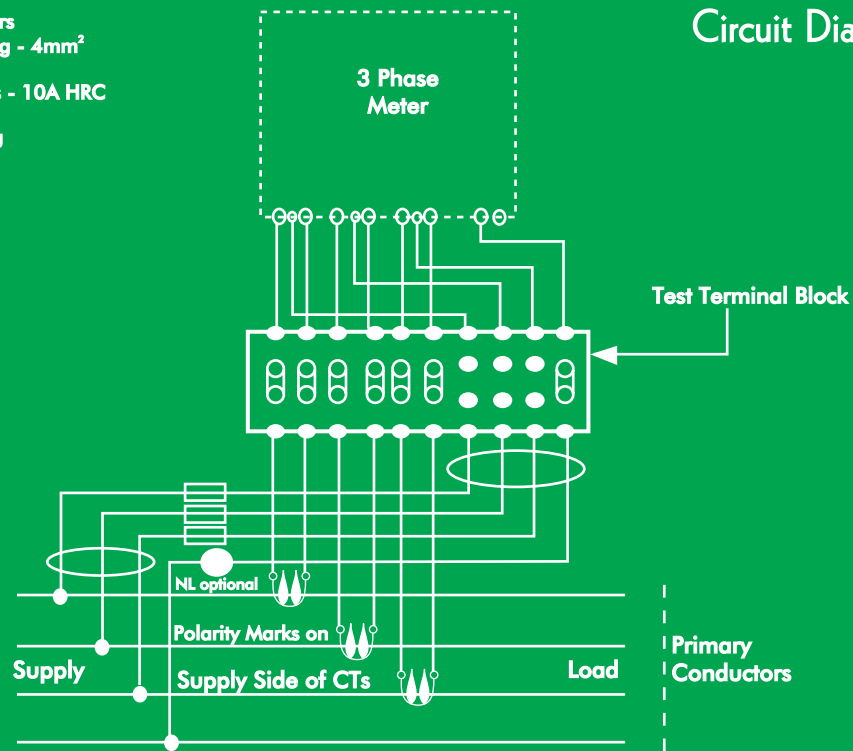

Manufactured by :



6, Laxmi Woollen Mills Compound, Shakti Mills Lane,
Off. Dr. E. Moses Road, Mahalaxmi, Mumbai - 400 011 India.
Tel.: +91-22-2494 6564 Fax : +91-22-2492 7335
E-mail : nelsterwelcon@hotmail.com • Website : www.nelsterwelcon.com